

Description		Assembly Order No.
Style 1T19L-7	Blind nuts, 1/4 NPT	W01-358-9148
	Blind nuts, 1/4 NPT, bumper	W01-358-9149
Two Ply Bellows	Blind nuts, 3/4 NPT	W01-358-9172
	Blind nuts, 3/4 NPT, bumper	W01-358-9160
	Countersunk steel bead ring	W01-358-9165
	1 3/4 bolts, nuts, washers	
Assembly weight		20.9 lbs.

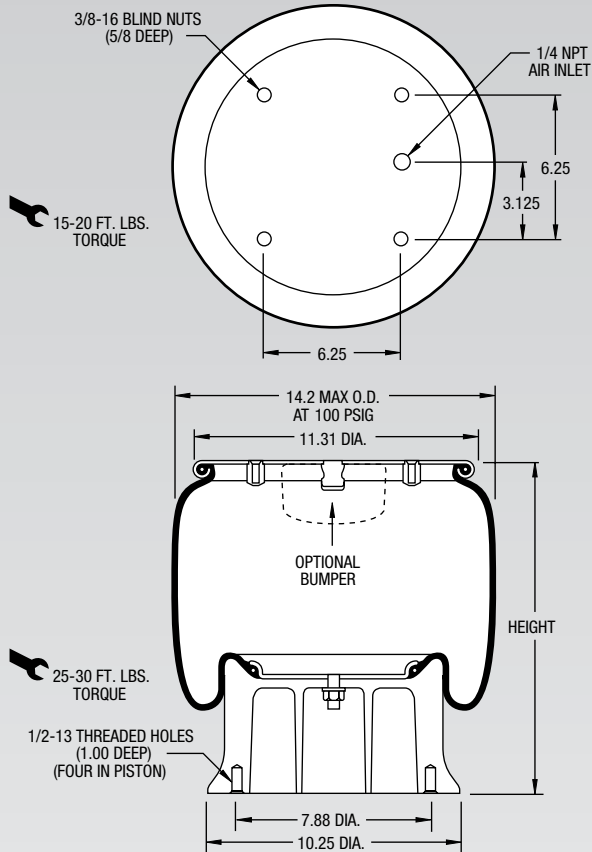

NOTE: Bellows will not compress properly with less than 20 PSIG internal pressure.

NOTE: A bead plate part is shown. This part is also available with a bead ring. Bolts are not included. See pages 8-10 for explanation.

Recommended Design Position Static Pressure 0-100 psi

CONSULT FIRESTONE BEFORE USING AS AIRMOUNT

RECOMMENDED AIRMOUNT DESIGN HEIGHT 13.0 INCHES

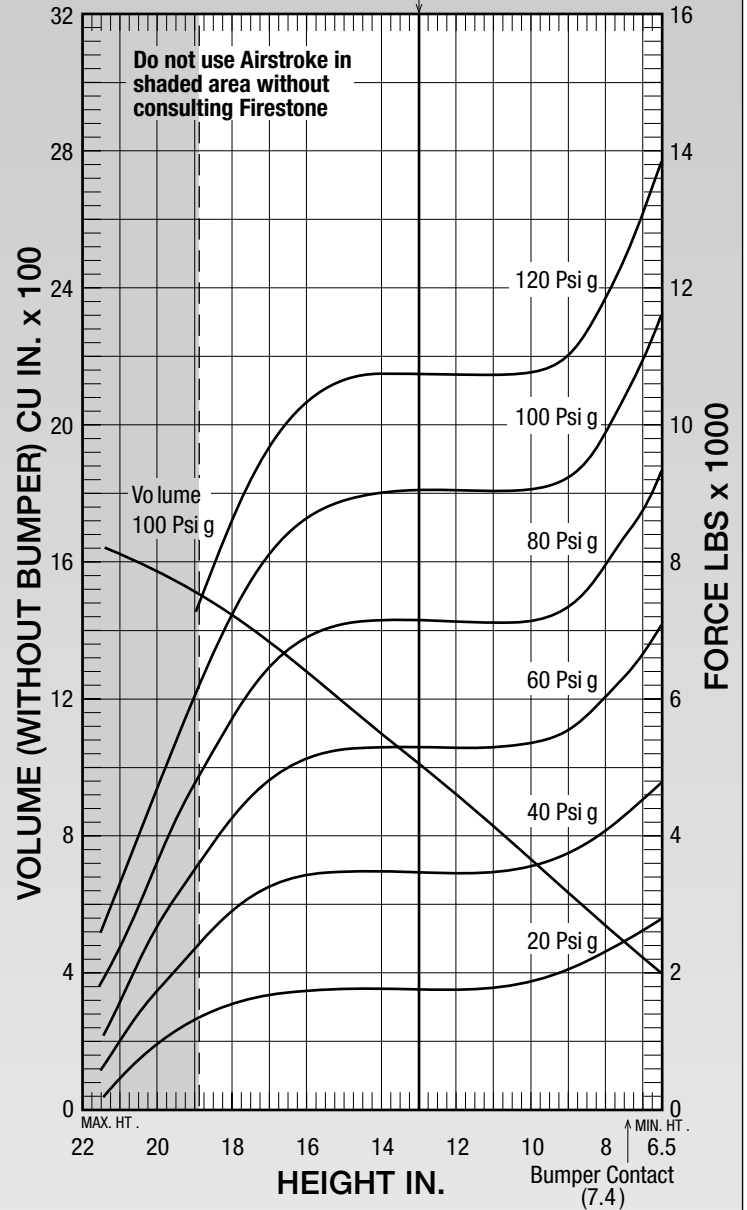

See page 12 for instructions on how to use chart.

Dynamic Characteristics at 13.0 in. Design Height (Required for Airmount isolator design only)				
Volume @ 100 PSIG = 921 in ³			Natural Frequency	
Gage Pressure (PSIG)	Load (lbs.)	Spring Rate (lbs./in.)	CPM	HZ
40	3,482	532	73	1.22
60	5,297	777	72	1.20
80	7,101	982	70	1.17
100	8,984	1,227	69	1.15

Force Table (Use for Airstroke™ actuator design)						
Assembly Height (in.)	Volume @ 100 PSIG (in ³)	Pounds Force				
		@20 PSIG	@40 PSIG	@60 PSIG	@80 PSIG	@100 PSIG
18.50	1,480	1,398	2,605	3,859	5,194	6,645
16.50	1,328	1,705	3,309	4,952	6,624	8,350
14.50	1,155	1,760	3,482	5,293	7,095	8,964
12.50	969	1,760	3,482	5,297	7,101	8,984
10.50	778	1,760	3,482	5,297	7,101	8,984
8.50	591	2,126	3,876	5,748	7,597	9,515